

LABORATORIES FOR THE 21ST CENTURY: CASE STUDIES

Case Study Index

Laboratory Type

- Wet lab
- Dry lab
- Clean room

Construction Type

- New
- Retrofit

Type of Operation

- Research/development
- Manufacturing
- Teaching
- Chemistry
- Biology
- Electronics

Service Option

- Suspended ceiling
- Utility corridor
- Interstitial space

Featured Technologies

- Fume hoods
- Controls
- Mechanical systems
- Electrical loads
- Water conservation
- Renewables
- Sustainable design/planning
- On-site generation

Other Topics

- Diversity factor
- Carbon trading
- Selling concepts to stakeholders
- Design process

LEED Rating

- Platinum
- Silver
- Bronze



Randy Montoya, Sandia National Laboratories/PIX10231

PROCESS AND ENVIRONMENTAL TECHNOLOGY LABORATORY AT SANDIA NATIONAL LABORATORIES, NEW MEXICO

Introduction

The Process and Environmental Technology Laboratory (PETL) is a new, state-of-the-art laboratory building on Sandia National Laboratories' Albuquerque, New Mexico, campus. Its primary occupants are staff in the Materials and Process Sciences Center, whose work focuses on the creation of new materials; development of process methods with an emphasis on process fundamentals, modeling, and control; and early detection and prediction of aging and reliability of materials. This study describes how the design team was able to reduce the energy consumption of the PETL by 40%. It is geared toward architects and engineers who are familiar with laboratory buildings. The study is one in a series produced by Laboratories for the 21st Century, a joint program of the U.S. Environmental Protection Agency (EPA) and the U.S. Department of Energy (DOE). This program encourages the design, construction and operation of safe, sustainable, high-performance laboratories.



United States
Department
of Energy





The challenge for the design team of this facility was to ensure energy efficiency while meeting the needs of the occupants. This required the design team to know and to meet the facility's requirements; apply the correct accounting and analysis methods to the design; and understand how an energy-efficient design can perform better. The design team ultimately reduced the projected energy consumption of the building by 40% in comparison to the baseline established in the initial building plan. Efficiency improvements were achieved using a wide range of building design technologies, including variable-air-volume (VAV) exhaust, heat recovery, thermal storage, and several others described in this report. Higher initial costs, about 4% of the total for construction, will be paid back from the long-term energy savings.

Project Description

The initial design for this project began in February 1996. Construction began in May 1998 and was completed in June 2000. Occupancy was completed in December 2000. The total building cost was \$28.5 million, resulting in a cost per square foot (ft²) of \$188 [\$2,025 per square meter (m²)].

The PETL contains 151,435 gross ft² (14,070 m²) with 53,000 net ft² (5,575 m²) of wet chemistry and materials laboratory space meeting Uniform Building Code (UBC)

H-6 occupancy. The H-6 designation requires, among other things, that the laboratory and chemical storage portions of the building meet exhaust ventilation requirements of not less than one cubic foot per minute (cfm) per square foot of floor area (UBC section 1202.25, 1997).

The three-story building is designed to house approximately 180 people, and it contains laboratories for aging and reliability studies, development of scientifically tailored materials, process exploration, materials characterization, and modeling. Scientists conduct research in polymers, ceramics, metals, and advanced analytical techniques. This work is key to all of DOE's missions. For the nation's nuclear weapons program, contributions range from understanding mechanisms at the atomic level to developing nuclear weapons components and evaluating the lifetime and reliability of the nuclear stockpile. For other national security programs, materials research provides capabilities from sensors used in treaty verification to warning systems for chemical and biological attacks.

Developments in materials and process sciences are also critical for DOE energy and environmental programs in areas such as advanced processes for efficient manufacturing, environmentally conscious manufacturing, and catalysts for improved energy conservation. Work at the laboratory also supports other Federal agencies, industrial partners, and universities.

To support research at the submicron level, the building's waffle slab construction significantly reduces floor vibrations. To ensure safe working conditions, the layout separates workers from chemicals, and laboratory air is not recirculated. The PETL has two videoconference rooms, seating areas for informal gatherings, small conference rooms, and a multiple-purpose room.

The building has a central core of laboratories, with offices on the perimeter. Much of the lighting for the office areas can be met by daylighting, since nearly every office has a window. The laboratory and utility infrastructures were designed with a modular layout to allow staff to rapidly reconfigure their research environments in a world of accelerating scientific and technological advances. Current laboratory types include organic chemistry, welding, thin films, ceramics and corrosion. Equipment in the laboratories includes 54 VAV fume hoods, scanning electron microscopes (SEMs), tunneling electron microscopes (TEMs), and magnetic resonance imagers (MRIs). Each laboratory area also includes a chemical free zone (CFZ) to allow researchers to work in their laboratories, away from the areas where chemicals are used. A fairly typical floor plan is shown in Figure 1.



Sandia National Laboratories/PIX10230

Daylighting provides much of the lighting in perimeter areas.

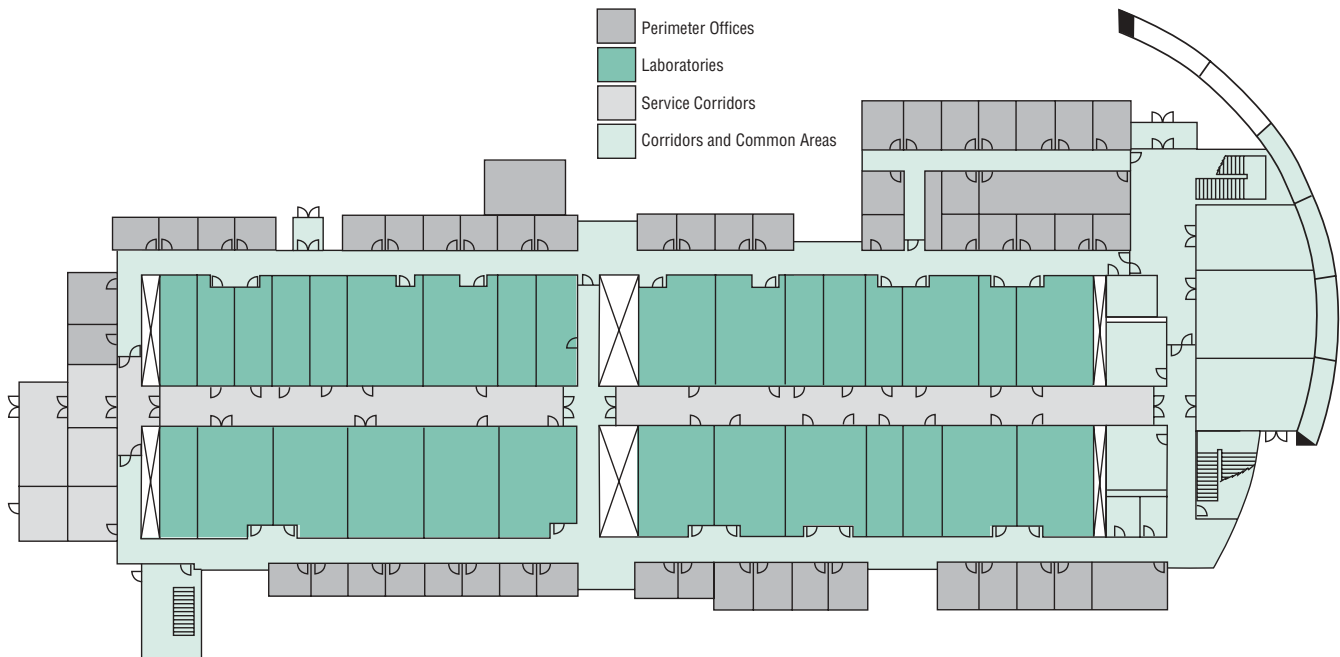
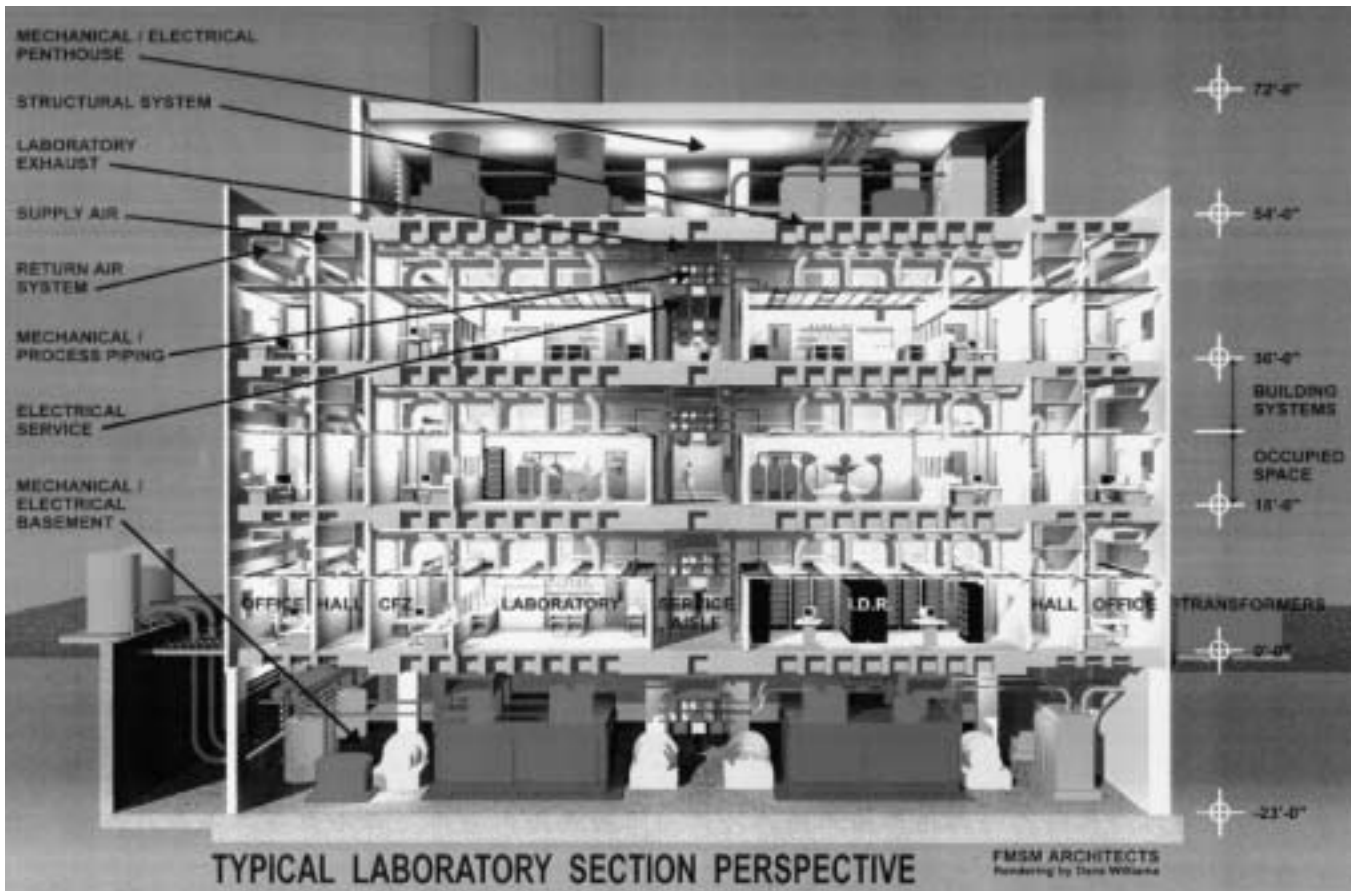

Figure 1. Typical PETL floor plan



Sandia National Laboratories

Figure 2. Cross section of the building



The facility's basement is 23 ft (7 m) deep, and it houses most of the major heating, ventilating, and air-conditioning (HVAC) equipment and electrical systems. This includes 2 laboratory air-handling make-up air units (MAUs); 2 office air-handling units (AHUs); 2 ring seal vacuum pumps; an air compressor with dryer for user air (supplied at 100 and 15 psi); an instrument air compressor with dryer for controls; a user deionized water system; and a boiler room with 10 pulse hydronic condensing boilers and separate domestic and process water heaters. Exhaust fans and additional mechanical and electrical systems are located in the penthouse of the facility. Each floor has a corridor for utility servicing that allows maintenance activities to occur without entering the laboratory spaces, and there is approximately 6 ft (1.8 m) of ceiling space above each laboratory for necessary equipment. A cross-sectional view of the building is shown in Figure 2.

Design Approach

The design cycle for this facility consisted of two phases. The Title I phase, which included programming and 35% design, had an energy baseline of 595,000 British thermal units (Btu) per square foot per year. In an effort to improve this before completing the design, Sandia's design team became significantly more involved with the Architect/Engineer, Lockwood Greene Technologies of Oak Ridge, Tennessee. Their combined effort improved the energy efficiency of the final design. At the completion of the Title II design phase (definitive design and construction documents), the energy intensity had been lowered to 341,000 Btu/ft²/yr, a 43% reduction.

The building process took almost 5 years to complete. Significant dates are listed in Table 1.

Efforts to improve efficiency began when the Title I Energy Conservation Report (ECR) showed an energy consumption estimate that exceeded by 20% the average annual energy use of Sandia's most energy-intensive facilities. This would have hurt Sandia's efforts to meet the DOE Order 430.2 energy-reduction goals for this category of building. DOE requires ECRs for facilities greater than 10,000 gross square feet (929 m²).

The initial focus was on producing a design that met the operational needs of the customer within the specified schedule and at the lowest cost. In this paradigm, it is assumed that designing for energy efficiency often lengthens the schedule and costs more. To realize the full worth of an energy-efficient design, however, the project needed to consider the life-cycle costs of the building as well as the conservation of resources and the societal benefits. The challenge for the design team, and ultimately the customer, was to know and meet the facility's requirements; apply the correct accounting and analysis methods to the design; and understand how an energy-efficient design can perform better and cost less.

By carefully considering cooling, heating, process, and electrical loads, the team produced a design that provided significant annual savings. Examples of energy-efficient design measures included right-sized and high or premium efficiency equipment; optimized systems; a well-formulated sequence of operations; optimized equipment run-time; and good commissioning, including control systems and training. These savings offset the higher initial costs paid for tighter envelopes and premium efficiency equipment. Savings are obtained through reduced mechanical equipment size and reduced costs for electricity, maintenance, water, natural gas, waste disposal, and chemicals. The benefit is a significant reduction in life-cycle costs.

The Code of Federal Regulations (CFR) provided additional guidance for efficient design. This includes 10 CFR 135, Energy Conservation Voluntary Performance Standards for New Buildings: Mandatory for Federal Buildings, and 10 CFR 436, Federal Energy Management and Planning Programs.

The process for incorporating energy-efficient measures into the Title II design for the PETL facility followed a typical design sequence. A key advantage was having energy experts involved in the process. Sandia's facilities energy manager assumed this role, with support from the energy manager in the DOE Albuquerque Field Office. As a consultant to the design team, the energy manager:

- Introduced the option of chilled water thermal storage during Title I design, matched it to project and site needs, and aided in preparing the justification.
- Provided recommendations on energy-efficient considerations and assisted with the analysis.
- Emphasized the importance of determining equipment diversity and right-sizing the HVAC and electrical equipment.

Table 1. Significant Project Dates

Planning and Construction Process	Started	Completed
Schematic design for the building (Title I)	February 1996	October 1996
Design submittal (Title II)	November 1996	September 1997
Construction (Title III)	May 1998	June 2000
Occupancy	July 2000	December 2000



- Provided guidance on compiling the ECR and determining which alternatives should be studied.
- Helped to ensure that an Energy Systems model was accurately completed for the base case design and each alternative. DOE 2.1E Energy Analysis Software was used.
- Ensured that a life-cycle costing (LCC) analysis, according to 10 CFR 436, was completed for the base case and each alternative considered.

For the ECR to serve as a value-added tool in the design decision process, the energy and LCC models had to be as accurate as possible, since final selection of systems hinged on the results. They had to accurately reflect the design, system sizes, and all building parameters. The analysis program, National Institute of Standards and Technology (NIST) Building Life-Cycle Cost (BLCC) version 4.3, calculates the present value of each building system (base case and alternatives) over its useful life. Inputs are first cost, annual energy use, applicable energy rates, and estimated maintenance costs. Other things being equal (e.g., the needs of the building occupants are being met), the system with lowest LCC is selected. Other economic evaluations, like savings-to-investment ratio (SIR, also called benefit-to-cost ratio) and annual return on investment (ROI), were used to confirm the selection.

The completed Title II design reduced the original energy baseline for PETL from 595,000 Btu/ft²/yr to 341,000 Btu/ft²/yr. Of this reduction, it is estimated that about 150,000 Btu/ft²/yr resulted from inclusion of more energy-efficient options into the design. The remaining reductions resulted from better accounting of energy consumption between the Title I ECR and the final ECR.

Technologies Used

The single largest energy consumer in the building is the ventilation air system required to maintain a safe laboratory environment. Thus the laboratory HVAC system was a major focus in design considerations. The LCC analysis, as applied by the design team, resulted in the selection of several energy-efficient alternatives for the PETL project. Some of the key measures are identified in Table 2.

Along with the efficient technologies listed in the table, other system improvements included variable-flow supply air, exhaust air, and water systems; VAV fume hoods; an energy management control system (EMCS); sunshades and reflective glass; lighting systems; and metering. These improvements are described in more detail below.

Variable-Frequency Drives for Fan Volume and Pump Control

Variable-frequency drives (VFDs) were selected over inlet vanes for all major fans on this project. This change allows the fans to run at slower speeds when loads are lighter, reducing energy consumption when maximum airflow is not required. This is potentially a 50%–60% savings over inlet vanes, which do not slow down the fan, but rather reduce the airflow available to the fan, without reducing energy use as much. Inlet vane controls were an option, because they meet the minimum requirements of 10 CFR 435.

The water system also uses variable flow technology; VFDs were provided on all of the larger pumps in the building. This allows the facility to pump only what is required to meet system needs. The main chilled water pumps from the existing central plant also use VFDs.

Table 2. Energy-Efficient Technologies Confirmed by LCC Analysis

Energy-Efficient Technologies	Expected Life (years)	Added Cost (\$)	Energy Saved per Year		Energy Savings (\$/year)	Simple Payback (years)
			Electrical (kWh/year)	Natural Gas (therms)		
Variable-frequency drives instead of inlet vanes for fan variable-volume control	10	109,600	1,082,300	0	61,700	1.8
Heat pipe energy recovery system with evaporative cooling	25	329,600	249,400	90,400	31,800	10.4
Chilled water thermal energy storage system.	25	239,500	55,670	0	104,000	2.3
Premium efficiency motors	10	6,930	54,700	0	3,200	2.2
Premium efficiency, multiple-boiler system	25	8,750	14,500	29,500	8,200	1.1



These 50-horse power (hp) pumps were vastly underutilized. Based on a hydraulic analysis, Sandia staff determined they had the capacity to serve PETL as well. This saved the cost of an additional pump, but more importantly made more effective use of an existing pump and saved the space, maintenance, and energy costs of an additional pump.

The EMCS controls water flow based on demand and water temperature. For the winter of 2000–2001, chilled water demand was consistently less than 100 tons, and as low as 10–15 tons. These savings were realized by demand-based, variable-volume pumping.

Heat Pipe Energy Recovery System with Evaporative Cooling

Modern chemistry laboratories require once-through air to meet regulations for employee health and safety. The single most important (and largest) application of energy recovery in research facilities is the energy recovery in laboratory exhaust systems. Under design conditions, PETL will exhaust about 150,000 cfm of expensive conditioned air from its laboratories. It takes a large amount of energy to filter, heat, or cool that much air. An energy recovery unit is used to extract as much of this energy as possible from the exhaust and transfer it to the incoming make-up air. Sandia selected heat pipe heat exchangers as the method of energy recovery.

Heat pipe heat exchangers transfer sensible heat between two airstreams using a counterflow configuration to maximize heat transfer and minimize pressure drop. The heat pipes are rows of copper tubes with aluminum fins partially filled with refrigerant and permanently sealed. Hot air flowing over the evaporator end of the heat

pipe vaporizes the refrigerant. A vapor pressure gradient drives the vapor to the condenser end of the heat pipe tube where the vapor condenses, releasing the latent energy of vaporization. The condensed fluid is wicked or flows back to the evaporator, where it is revaporized, completing the cycle. Thus, the heat pipe's refrigerant operates in a closed-loop evaporation/condensation cycle that continues as long as there is a temperature difference to drive the process. This mechanism allows heat transfer along a heat pipe to be up to 1000 times faster than it is through copper. Heat pipe heat exchangers have a typical effectiveness range of sensible heat transfer of 45%–65%. (American Society of Heating, Refrigerating and Air-Conditioning Engineers, Inc., *2000 ASHRAE Handbook—HVAC Systems and Equipment*, 44.16)

With over 50% recovery, both heating and cooling requirements are significantly reduced in this facility. Additional cooling efficiency was achieved by adding a 1 ft (0.3 m) deep cellulose media evaporative cooling section to the exhaust-air side of the heat pipe heat exchanger. This system uses reverse osmosis (RO) water to minimize scaling. The exhaust system and intake air are intentionally routed adjacent to one another in the penthouse in order for the heat pipe system to recover the energy contained in the exhaust stream. See Figure 3 for additional detail on the heat pipe system. Tables 3 and 4 show design and test performance data on the heat pipes and evaporative cooling system.

Chilled Water Thermal Energy Storage System

The thermal energy storage (TES) system, while not physically part of PETL, was funded by this project and

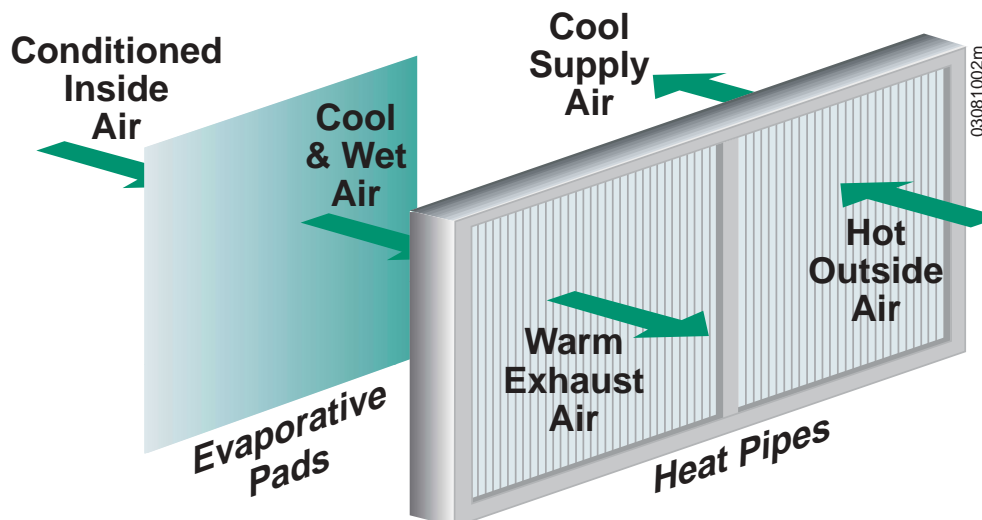

Figure 3. Heat pipe system



Table 3. Performance Data on Heat Exchanger Section

Season	Supply			Exhaust			Sensible Energy Recovery (Btu/hr)		
	Air Flow (CFM, Standard Conditions)	Temp °F (Dry Bulb/Wet Bulb)		Pressure Drop Across Heat Exchanger (Inches of Water)	Air Flow (CFM, Standard Conditions)	Temp °F (Dry Bulb/Wet Bulb)		Pressure Drop Across Heat Exchanger (Inches of Water)	
		In	Out			In			Out
Winter Weather Design Performance	151,300	12/10	45/31	1.27	151,300	72/60	46/46	1.42	4,443,681
Summer Weather Design Performance	151,300	97/61	77/53	1.45	151,300	58/56	78/63	1.37	2,693,140
Moderate Weather Actual Performance	152,200	84/59	75/57	0.50	151,800	58/56	59/69	0.50	1,219,122

Table 4. Performance Data on Evaporative Section

Season	Evaporative			
	Air Flow (CFM, Standard Conditions)	Temp °F (Dry Bulb/Wet Bulb)		Pressure Drop Across Evaporative Section (Inches of Water)
		In	Out	
Summer Weather Design Performance	151,300	72/56	58/56	0.22
Moderate Weather Actual Performance	151,800	72/56	58/56	0.20

is the first of its kind at Sandia. The funds that were estimated for chilled water production in PETL were instead used to enhance the efficiency of an existing on-site central chiller plant that would become the chilled water source for PETL. This provided the laboratory with a less expensive and more reliable source of chilled water while leveraging funds to save energy costs for the 10 other buildings connected to the plant. Since Sandia is on a time-of-use electricity rate structure, the energy cost savings are obtained by producing chilled water at night when electricity rates are low, and keeping two of the three 1100 hp centrifugal chillers off during the day when rates are higher. This system stores more than 1 million gallons, delivering 10,000 ton-hours of chilled water.

This TES system is unusual because it provides more than a shift of energy use from high peak costs to off-peak costs. Integrating the TES system into an existing chilled water plant meant that many efficiency improvements had to be made so the chilled water TES system would function as intended. An energy audit of the chilled water

plant in November 1998 confirmed that chilled water was being overpumped and wasting energy, leading to overuse of the pumps and reduced chiller efficiency.

The design capacity of the existing chillers and the new TES system was based on a 15 °F (8.3 °C) difference between supply and return water temperature (ΔT), while the chilled water plant was commonly achieving a ΔT of only 8 °F (4.4 °C) or less. Variable-volume pumping was added to the primary loop, and the existing variable-volume 50 hp pumps, mentioned above, were more effectively used. Final implementation of the TES system occurred when a constant-volume secondary loop was converted to variable volume. When that occurred, there was an immediate 50%–60% drop in over-pumping and the design ΔT was achieved. Approximately 500 tons of chilled water capacity was restored.

The energy audit also revealed that the 1100 hp chillers are most efficient at full load, and this efficiency drops fairly linearly as the load drops. Therefore, further energy savings are achieved by charging the TES tank at night with chillers operating at close to their best efficiency point rather than in a variable load during the day. Cooling towers also are more effective in the lower dew point temperatures at night. Recently, another secondary loop was changed to variable-volume, further adding to the operational improvements and energy savings of the central plant.

Another feature of the system—used for control, monitoring, and billing purposes—is the application of Btu energy meters on the chilled water distribution to the secondary loops. This was another first for Sandia, and is becoming the standard for new chilled water system designs and modifications. The Btu meters consist of separate flow and temperature sensors, with outputs



integrated into a single control box to give Btu readings. The flow outputs are used to control the primary loop VFDs, and the Btu outputs are used by the facilities energy management office to accurately allocate electric consumption (in the form of chilled water) to the connected buildings. Sandia received a DOE Departmental Energy Management Award for the Chilled Water Thermal Energy Storage System in August 2001.

Premium Efficiency Motors

Premium efficiency motors were applied to all HVAC applications requiring greater than 30 hp and having high annual run times. This produced the energy savings and 2.2-year simple payback shown in Table 2, even when compared with a baseline of high-efficiency motors (the standard since October 1997 according to the Energy Policy Act of 1992). Premium efficiency motors are also better matched to VFD operation than high-efficiency motors, increasing expected motor life.

Premium Efficiency, Multiple-Boiler System

Hot water is provided to the building by 10 pulse hydronic condensing boilers. Each of the 1.4 million Btu premium efficiency pulse boilers is about the size of a large refrigerator and can achieve as high as 98% efficiency when operating in the condensing mode. To maximize efficiency, the number of boilers operating and the supply temperature are determined by the EMCS. Another benefit is that these boilers use less floor space than equivalent output noncondensing boilers do.

Variable-Flow Supply Air, Exhaust Air, and Water Systems

PETL uses two independent systems that provide general building air supply and exhaust. One provides air to the laboratories and chemical free zones (CFZs); the other feeds the offices and common areas of the building. The design team selected VAV systems, which use VFDs on fans to control the variable airflow, rather than inlet vane controls.

Two large MAUs are located in the basement; they supply air to the north and south laboratory/CFZ sections of the building. The supply is 100% outdoor air, with no air recirculation. The two fan systems are interconnected to allow one unit to serve the entire building in case of failure. They are also divided to allow for different supply air temperatures to prevent over-cooling the entire facility to meet the highest load areas. Each unit uses hot and cold water coils to temper the air to the desired delivery setpoint. The outdoor air provided to the MAUs is filtered with bag filters, then preheated or cooled through the heat recovery system. At the MAUs, the air is further filtered and supplied at a constant duct pressure, maintained by

VFDs, to the laboratory/CFZ areas by an insulated metal duct system.

Each individual laboratory controls the amount of air delivered to and exhausted from the space to satisfy pressure offsets as well as temperature. For temperature control in the laboratory zones, the make-up air provides cooling, and local re-heat coils provide heating. Each laboratory has a local controller tied into the EMCS that monitors all of the exhaust from fume hoods, snorkels, other equipment, and the general room. The local controller totals these exhausts, subtracts a predetermined offset volume, and adjusts the volume of incoming air to maintain the negative pressure of the laboratory and the required air changes per minute. The main MAUs and exhaust fans adjust air volume to meet only what is required by the laboratories at any given moment. This system also gives laboratory users the flexibility to add or remove items from the exhaust systems in their laboratories as needed, because the airflow adjusts automatically to maintain the required system pressure. This airflow may be reduced further with additional equipment.

One of the significant lessons learned on this project was the sizing of the airflow monitoring stations. The monitoring stations were oversized with the original ductwork, to allow for much larger fans than were required by the building. Although the fan size and airflow were reduced during the design process, the flow stations' ability to measure airflow was not. Thus, the minimum level of control is 150,000 cfm. If the airflow stations were changed to allow for smaller readings, the airflow could be reduced even further. The expense of this equipment change could be prevented in future buildings that begin with a more efficient design. Sandia is currently analyzing the costs of replacing the sensors. The energy savings will be significant, and the simple payback period should be short.

In addition to the laboratory/CFZ system, two AHUs are interconnected to feed the offices and common areas. These units use a combination of filtered outside air and return air to provide conditioned air to the space. The air-handlers utilize hot and cold water coils to temper the air to the desired setpoint. Conditioned air is delivered through insulated ducts to VAV boxes with reheat coils. Fan speed is controlled by duct static, and the speed slows down as the demand for cooling in the space is satisfied. During 80% of the year, combined ductwork allows one fan to maintain office air requirements while two fans run only during the periods of the highest loads.

VAV Fume Hoods

The fume hoods used in PETL are VAV-type with partial bypass. The hoods are designed to provide a set



face velocity at any sash position. The partial bypass feature allows air to enter the hood under the airfoil bottom sill and through an opening above the sash. This airflow ensures that the hood will continue to capture fumes while the sash is closed, and when it is first opened. There are currently 54 such fume hoods in this facility.

Control of the hoods is achieved with an EMCS control module, a user interface module on the front of the hood, a butterfly-type control damper with pneumatic actuation, and an air flow-measuring sensor. See Figure 4 for the system layout.

As a sash is opened or closed, the user interface panel indicates the face velocity in feet per minute. This number is derived from the sash position and corresponding open area. The fume hood controller will open or close the exhaust control damper to get the flow that corresponds to the sash position. This flow is monitored by the EMCS to verify that it is working properly. The flow is also used by the EMCS to calculate the total flow required by the laboratory, and the general exhaust is adjusted accordingly.

The EMCS also sends the position of the fume hood sashes to the Environmental Safety and Health (ES&H) coordinator in the building. For ES&H, this information indicates which hoods are being left open and how much exhaust air certain personnel are using. With the fume

hood sashes open, a laboratory exhausts more expensive conditioned air than it would with the sashes closed, and hood safety increases when the sash is closed. Another feature is that ES&H can confirm that all sashes are closed when the system requires it. In other Sandia buildings, this can only be achieved by physical verification of each fume hood. Monitoring this information allows ES&H to encourage safer and more energy efficient use of the fume hoods.

Energy Management Control System

Direct digital controls (DDC) are used for the HVAC building systems, and the EMCS provides a central computer station in the maintenance office with approximately 600 distinct control points and graphic displays of data for the AHUs, MAUs, exhaust fans, fume hoods, room temperatures, water systems, pumps, heat exchangers, and central utility consumption. Alarms and maintenance reminders are displayed automatically. This enables the facility maintenance staff to control, trend, and monitor all the equipment throughout the building. Fume hoods are also monitored in the ES&H office, as mentioned above.

The EMCS monitors and varies the flow of air throughout the various building systems as needed to meet building and customer requirements. The fume hood system maintains a negative pressure at all times relative

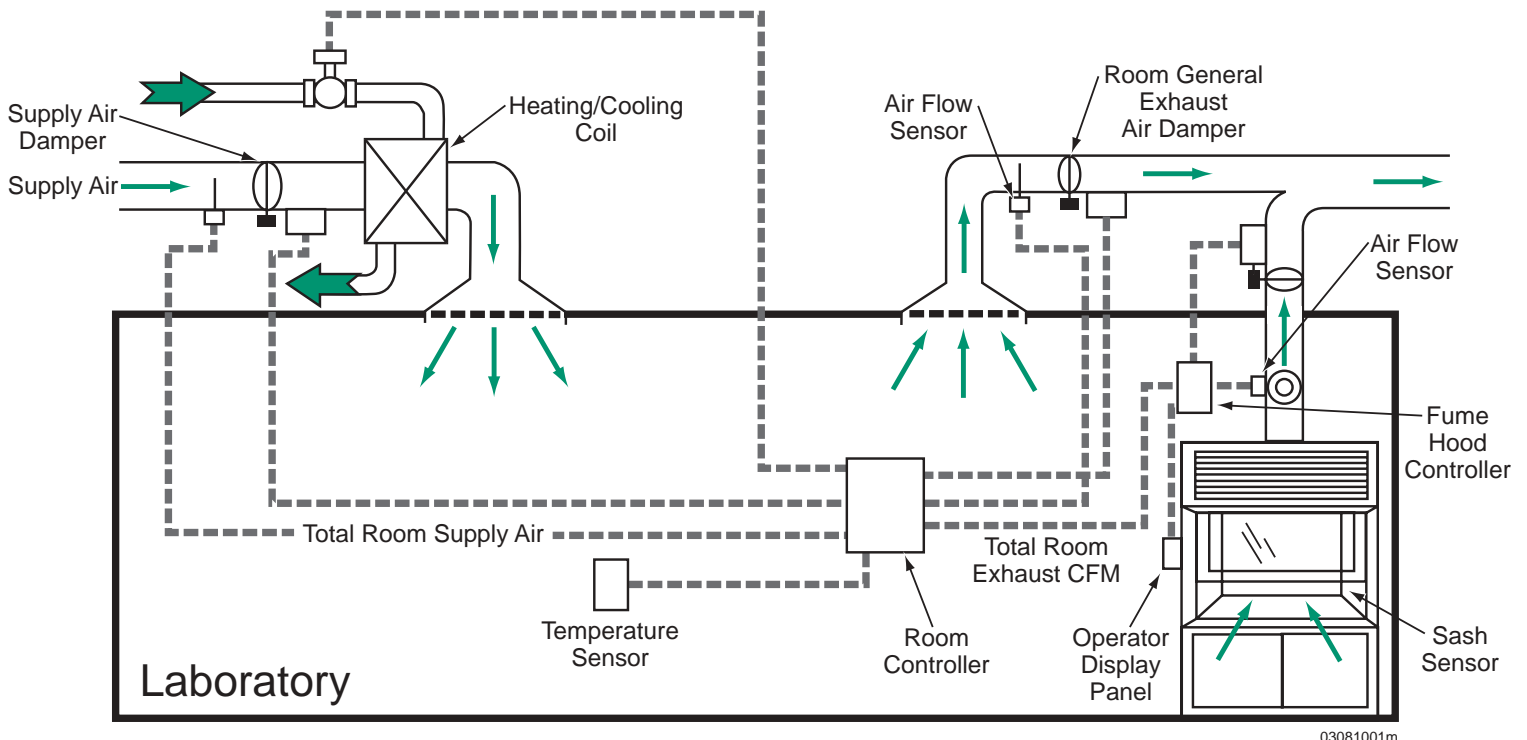

03081001m

Figure 4. VAV laboratory control system (information courtesy of Siemens Building Technologies, Inc., and CAC, Inc., the PETL system installing contractor)



to the to laboratory space pressure, in order to draw fumes out of the laboratories. The total laboratory area exhaust system maintains a negative pressure relative to the offices and common spaces, such as hallways. The offices and common areas are maintained at a positive pressure relative to the outdoors, in order to keep dirt from being drawn into the building. All of this is coordinated to keep energy consumption as low as possible.

Sunshades and Reflective Glass

Sunshades cover all the south-facing glass exposures. This system blocks the hot summer sun, while allowing the winter sun to enter and help warm the building's interior. This saves cooling energy in the summer, while contributing heating energy in the winter. Side shields on the shades help block low-angle sun and reduce airflow across the glass that would further add to heating or cooling losses.

High-efficiency, reflective glazing is used for windows throughout PETL. This glass has a reflective film that controls unwanted solar heat gain by reflecting and absorbing a majority of the sun's radiation, while allowing beneficial light to enter. The glass should also help reduce glare to the offices in winter.

Lighting

PETL features efficient lighting technology. The target was 1 watt (W) per square foot of connected lighting load. All the fluorescent light fixtures use T-8 lamps with electronic ballasts, and the building uses light-emitting diode (LED) exit signs, both of which have become the

standard at Sandia. Also contributing to energy savings are the programmable lighting control system for the labs; the occupancy sensors in the halls, conference rooms, break rooms and bathrooms; and the natural lighting available to the perimeter offices. The ECR showed that the target of 1 W/ft² (0.09 W/m²) connected load was met. Actual operation is about 0.75 W/ft² (0.07 W/m²).

Discussions during the lighting system design included how to cost-effectively and functionally address lighting control. The design team decided to use the programmable lighting control system only in the laboratories, where occupancy sensor-based control would be ill advised. Occupancy sensors would only be used in the common areas, where there is typically no "ownership" of the light switch. In the individual offices, single light switches achieve the lighting control. The occupants can switch them off if natural light is sufficient or when they leave their offices. A lesson learned is that most occupants are not likely to flip off their light switches during the day, though studies have shown that if dimmable lighting systems are provided, with convenient control, occupants are likely to dim their lights to save energy and to have less glare on their computer screens.

Metering

All energy flows to the PETL facility are metered. This includes process load electricity, building electricity, natural gas, and chilled water. The electric meters communicate electronically to a central power monitoring system so load profiles can be monitored. An example of the process



Sunshades protect windows from the hot summer sun.

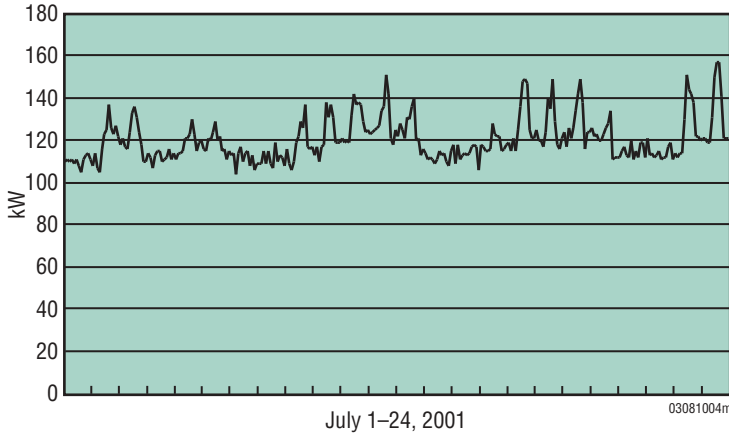

Figure 5. Daily Process Power Profile for PETL

load profile is shown in Figure 5. Electric use, gas use, and chilled water use are recorded each month. Total water use is also metered. Metering of lighting was considered late in the design of the project, but it was not implemented. Actual energy use of the facility is being compiled on an annual basis and compared with projected energy use determined by the ECR.

Commissioning Process

The PETL project included a detailed commissioning specification. The process used for this project was considered a “total commissioning activity.” It required that all installed systems be tested in an integrated manner for full functional performance. Integrated whole-building system commissioning is an important part of many new construction projects. The intent of the commissioning process is to:

- Start with conceptual design;
- Give customers what they expect and what the designers intended;
- Uncover problems early and implement solutions;
- Provide essential information for sequence of operations reviews; and
- Tie the entire project together.

The commissioning process for PETL began at the conceptual design

phase and continued throughout the project. In fact, PETL’s team of systems engineers continued the process through the winter heating season and resumed again after the construction was complete in the summer cooling season. The goal was to avoid the assumption that commissioning a project is something that occurs only after a project is complete, and only on the mechanical systems. Functional testing was only a small part of the total commissioning process.

To meet the operational needs of the customer, the commissioning specification put more responsibility on the contractor to ensure that the building would operate as intended. The general contractor hired a third party test engineer to carry out the contractor’s commissioning requirements. The contractor had control of the test and balance work that had traditionally been administered by Sandia. The contractor also became responsible for the controls software. Sandia would review this work, but not coordinate or control it. The contractor could be more easily held accountable for work they could control.

Table 5. Building Metrics

System	Key Metrics	Annual Energy Use (based on design data) ⁽¹⁾	Annual Energy Use (based on measured data)
Ventilation	Exhaust = 1.4 W/cfm Supply = 1.4 W/cfm ⁽²⁾ Total = 1.4 W/cfm (3 cfm/net ft ²) (1 cfm/gross ft ²)	25.8 kWh/gross ft ² ⁽³⁾ (73.6 kWh/net ft ²)	Not separately analyzed (NA)
Cooling Plant	570 ton peak 0.8 kW/ton average	10 kWh/gross ft ²	6.6 kWh/gross ft ²
Lighting	1.0 W/gross ft ²	2.7 kWh/gross ft ² ⁽⁴⁾	NA
Process/Plug	1.8 W/net ft ² measured average 2.7 W/net ft ² measured peak 6 W/net ft ² design	18.1 kWh/gross ft ² (52 kWh/net ft ²)	5.6 kWh/gross ft ² (16 kWh/net ft ²)
Heating Plant		147,880 Btu/gross ft ²	122,200 Btu/gross ft ²
Total		56.6 kWh/gross ft ² for electricity	43 kWh/gross ft ² for electricity
		193,120 Btu/gross ft ² for electricity	146,800 Btu/gross ft ² for electricity
		341,000 Btu/gross ft ² combined site for electricity and gas ⁽⁵⁾	269,000 Btu/gross ft ² combined site for electricity and gas ⁽⁵⁾

Notes:

1. Values from Energy Conservation Report unless otherwise noted.
2. 300 hp x 746 W/hp/160,000 cfm = 1.4 W/cfm, typical supply and exhaust.
3. Based on nameplate hp ratings.
4. Actual operation assumed to be 0.75 W/ft² /1000W/kW x 3600 hours = 2.7 kWh/ft².
5. Presented in site Btu (from actual energy bills for 9/00 to 8/01). To convert to source Btu for electricity by 3. Note that Albuquerque has 4297 heating degree days and 1239 cooling degree days.



Problem solving, long-term planning, life-cycle considerations, and energy-efficient design became the focus, rather than merely producing a design to meet the operational needs of the customer within the specified schedule and at the lowest up-front cost. For this project, commissioning was a proactive step that allowed improvements to be made and incorporated as the project moved from conceptual design through completion. The process acknowledged that the building was not perfect, and that each step should accommodate improvements in quality and efficiency. It also identified lessons learned, for future design and construction projects.

The Sandia design team's early involvement in the project improved projected energy use from a baseline of 595,000 Btu/ft²/yr to a final design projection of 341,000 Btu/ft²/yr. This is just one of the indications that ongoing involvement in the design process was useful in achieving greater efficiency and lower long-term costs.

Measurement and Evaluation Approach

The extent of the metering and EMCS monitoring and control will allow the PETL's team of systems engineers, the EMCS office, and the facilities energy manager to compare the facility's actual energy usage to projected usage, and they can continue to look for areas of potential improvement.

Summary

This case study shows the benefits of integrating both energy efficiency and flexibility into a building's design. The innovative strategies used in designing the PETL building demonstrate the advantages of using a total commissioning process that allows for continual design improvements. Planning for the long term, rather than merely meeting short-term operational needs, has resulted in a building that will cost less not only in terms of energy use and equipment maintenance but also in terms of societal and resource costs, well into the future.

Acknowledgments

Thanks are due to Jerry Savage and Ralph Wrons of Sandia National Laboratories and to Karri Shackelford and Otto Van Geet of the National Renewable Energy Laboratory for their contributions to this "Laboratories for the 21st Century" case study.

For More Information

Phil Wirdzek
U.S. Environmental Protection Agency
1200 Pennsylvania Ave., N.W.
Washington, DC 20460
202-564-2094
Wirdzek.Phil@epamail.epa.gov

Will Lintner, P.E.
Federal Energy Management Program
U.S. Department of Energy
1000 Independence Ave., S.W.
Washington, DC 20585
202-586-3120
william.lintner@ee.doe.gov

Ralph Wrons, P.E.
Facilities Energy Manager
Sandia National Laboratories
PO Box 5800, MS 0933
Albuquerque, NM 87185-0933
505-844-0601
rjwrons@sandia.gov

Otto Van Geet, P.E.
Federal Energy Management Program
National Renewable Energy Laboratory
1617 Cole Blvd.
Golden, CO 80401-3393
303-384-7369
Otto_VanGeet@nrel.gov



Laboratories for the 21st Century
U.S. Environmental Protection Agency
Office of Administration and Resources Management



In partnership with the
U.S. Department of Energy
Office of Federal Energy Management Programs

Prepared at the
National Renewable Energy Laboratory
A DOE national laboratory

DOE/GO-102001-1462
December 2001

Printed with a renewable-source ink on paper containing at least 50% wastepaper, including 20% postconsumer waste